

U & W - MULTIPLE LEG STARBARS, SILICON CARBIDE HEATING ELEMENTS

GENERAL DESCRIPTION

Made of high density recrystallized silicon carbide, these multiple leg Starbars use the same hot zone and cold end material as the RR type Starbars and offer a configuration that allows the electrical connections to be made at one end. The low resistance terminal ends (LRE) provide a high electrical resistance ratio to the hot zone section (>15:1). The first several inches of the cold ends are metallized with aluminum to provide a low electrical resistance contact surface. The electrical connections are made using flat aluminum braids held in compression to the circumference by a stainless steel spring clamp. U type Starbars are described by their overall length, the hot zone length, the cold end length and the nominal leg diameter.

Example: U 23.5 x 12 x 9.5 x 1 is a Starbar 23.5" overall with a 12" hot zone, 9.5" cold ends and 1" in diameter (U 597 x 305 x 241 x 25 is a Starbar 597mm overall with a 305mm hot zone, 241mm cold ends and 25mm diameter).

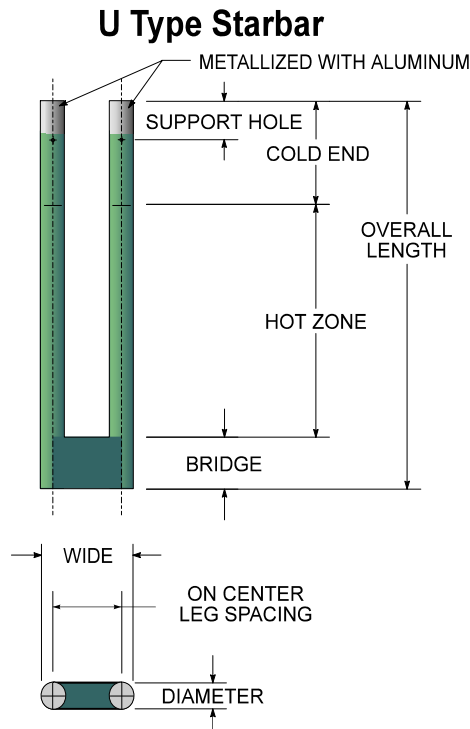

SUPERIOR PERFORMANCE

Starbars have superior performance due to their high density -- approximately 2.52 g/cc. This gives the Starbar very slow aging characteristics and high mechanical strength.

INTERCHANGEABILITY

Starbars are the only silicon carbide heating elements manufactured in the United States, and are interchangeable with heating elements of similar design as well as higher resistance heating elements manufactured for the Asian and European markets. It is important to provide the nominal electrical resistance when specifying Starbars.

SIZES AVAILABLE

Starbars can be manufactured in any length up to 110 inches (2800mm). Please see Table D, page 7, for diameters and recommended maximum lengths.



Silicon Carbide Heating Elements



I SQUARED R ELEMENT CO., INC.

OPERATING TEMPERATURES

All multiple leg Starbars can operate at furnace temperatures up to 2600 °F (1425°C). The hot zone material is rated to furnace temperatures up to 3100°F (1700°C). The restriction on the temperature relates to the terminal or cold end portion of the Starbar. If temperatures higher than 2600°F (1425°C) are required, the cold end section should be protected from the full furnace chamber temperatures.

The maximum operating temperature should be reduced for non-air applications. Only argon and helium can be used without any reduction of maximum operating temperatures. Reducing atmospheres - hydrogen or disassociated ammonia, particularly with low dew-points remove the protective silicon oxide that naturally forms on silicon carbide. In these atmospheres the chamber control temperature can not exceed 2500°F (1370°C). Please refer to Figure 1.

Nitrogen atmosphere applications are limited to 2500°F (1370°C) and 20 to 30 watts per square inch (3.1 to 4.6 watts per square centimeter) maximum watt loading. Too high a surface temperature will result in a silicon nitride reaction. A thermally insulating layer forms around the Starbar resulting in very high surface temperatures which damage the Starbars.

ELECTRICAL CHARACTERISTICS

The silicon carbide Starbar is a linear type resistance heater that converts electrical energy to heat energy -- Joule's Law $W = I^2 \times R$, (W = power in watts, I = current in amperes, R = resistance in ohms).

The Starbar hot zone is a self bonded silicon carbide. The lattice structure or bonds that hold the silicon carbide grain together are formed by recrystallizing the silicon carbide at very high temperatures. Starbars are manufactured of green silicon carbide that is classed as an excess electron type semiconductor.

The electrical resistance of a Starbar is difficult to measure at room temperature due to minor impurities, self heating, and contact resistance. Also the green silicon carbide has a negative resistance temperature characteristic from room temperature to approximately 1200°F (650°C). It turns positive at this point and remains so throughout its normal operating temperature range. A typical resistance temperature characteristic curve of a Starbar is shown in Figure 2.

Nominal Starbar resistance is measured at the calibrating temperature of 1960°F (1071°C). Nominal resistance values of Starbars in ohms, per unit of length, are shown in Table A, page 4.

Recommended Maximum Watt Loading (Figure 1)

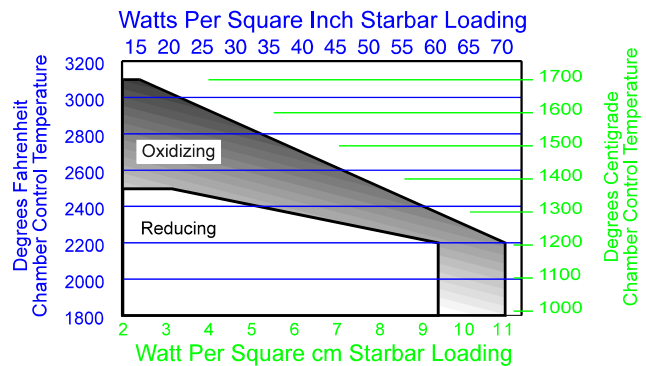

ELECTRICAL LOADING

Starbars are not sized to a specific wattage output like metallic heating elements. The amount of energy that a Starbar is capable of converting from electrical to heat energy depends on the ambient furnace temperature and atmosphere in which the Starbar is operating.

When calculating the wattage capabilities of a Starbar, the unit of watts output per unit of radiating surface area is used. Figure 1 shows the recommended watt loading for a square inch or square centimeter of radiating surface as a function of furnace temperature.

To determine the recommended wattage capabilities of the Starbars start with Figure 1. Knowing the furnace temperature and atmosphere in which the Starbars will be operated, follow the temperature line until you intersect the heavy black line (choosing the appropriate line according to the atmosphere in which the Starbar will be operating). Read the loading in watts per square unit of radiating surface that can be applied to the Starbar. To find the total amount of power one Starbar could supply under these conditions, multiply this value by the radiating surface area of the Starbar. The radiating surface area is calculated by multiplying the diameter times the hot zone length times pi (3.142) times the number of legs (2 for U, 3 for W).

Resistance Temperature Characteristics (Figure 2)

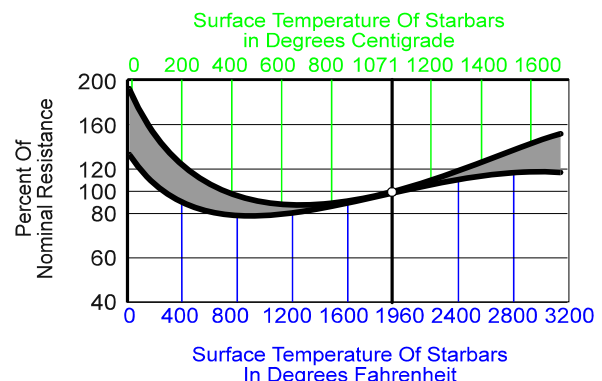

Starbars are test calibrated at a nominal surface temperature of 1960°F (1071°C).

Example: At 2600°F the Starbar could be loaded to 45 watts per square inch. Therefore, a Starbar with 10 square inches of radiating surface could supply 450 watts, whereas a Starbar with 200 square inches of radiating surface could supply 9000 watts.

At 1425°C the Starbar could be loaded to 7 watts per square centimeter. Therefore, a Starbar with 100 square centimeters of radiating surface could supply 700 watts, whereas a Starbar with 2000 square centimeters of radiating surface could supply 14,000 watts.

Example of radiating area: The U 23.5 x 12 x 9.5 x 1 has a hot zone length of 12 inches and diameter of 1 inch. The radiating surface area per leg is 12 x 1 x 3.142, or 37.5 square inches. This U has two legs, for a total surface area of 75 square inches. The W, with three legs, has a total surface area of 113 square inches.

The U 597 x 305 x 241 x 25mm has a hot zone length of 305 millimeters on a diameter of 25mm. The radiating surface area per leg is 305 x 25 x 3.142 or 23,943 square millimeters converted to centimeters is 239 square centimeters. This U type has two legs, for a total surface area of 479 square centimeters. The W, with three legs has a total surface area of 718 square centimeters.

POWER SUPPLY

The previous paragraph explained how to calculate the recommended wattage output of the Starbar. The following explains how to compute the electrical requirements to provide the recommended power.

Knowing the wattage output and the resistance of the Starbars supplies two parts of the three variables of the following equation: $V = \sqrt{W \times R}$, (V = nominal full load voltage, W = rating of the Starbar in watts, R = resistance of the Starbar in ohms). The resistance of the Starbar can be calculated using the values found in Table A, page 4.

Solving for V determines the voltage required to provide the wattage output desired. This assumes a nominal resistance.

Example: A Starbar U 23.5 x 12 x 9.5 x 1 has a resistance of 1.27 ohms and 75 square inches of radiating surface. Loading to 38 watts per square inch, this Starbar could provide 2850 watts.

A Starbar U 597 x 305 x 241x 25 has a resistance of 1.27 ohms and 479 square centimeters of radiating surface. Loading to 5.9 watts per square centimeter, this Starbar could provide 2850 watts.

To find the nominal voltage solve for V.

$$\begin{aligned}V &= \sqrt{W \times R} \\V &= \sqrt{2850 \times 1.27} \\V &= 60 \text{ volts}\end{aligned}$$

Starbars may be connected in parallel, series, or combination thereof. Parallel connections are preferred. In a parallel arrangement the voltage across all the Starbars is the same. In the formula $W = V^2 \div R$, (W = watts, V = voltage, R = resistance) it can be seen that the greater the resistance, the lower the wattage output. The Starbars in the parallel circuit with the lowest resistance will supply more heat energy and therefore operate at a higher temperature. This higher Starbar temperature will cause it to gradually increase in resistance until all the Starbars have the same resistance. At this time the Starbars should all have approximately the same resistance values and surface temperatures and therefore remain in balance.

To compute the network resistance of a group of Starbars, the following formula may be used: $R_n = R \times S \div P$ (R_n = network resistance, R = resistance of Starbar, S = number of Starbars connected in a series, P = number of parallel circuits).

Example: Eight Starbars U 23.5 x 12 x 9.5 x 1 (R = 1.27 ohms) connected 2 in series (S = 2) and 4 parallel groups (P = 4).

$$\begin{aligned}R_n &= R \times S \div P \\R_n &= 1.27 \times 2 \div 4 \\R_n &= 0.635 \text{ ohms}\end{aligned}$$

To compute the nominal voltage required to power a set of Starbars, we shall use a combination of the formulas used in the two previous examples. $V_n = \sqrt{W_t \times R_n}$, (V_n = nominal network voltage, W_t = total wattage output, R_n = network resistance).

Example: Eight Starbars U 23.5 x 12 x 9.5 x 1 (R = 1.28 ohms) connected 2 in series, 4 parallel groups, each Starbar provides 2850 watts. $W_t = 8 \times 2850 = 22,800$ watts, $R_n = 0.635$ ohms.

$$\begin{aligned}V_n &= \sqrt{W_t \times R_n} \\V_n &= \sqrt{22,800 \times 0.635} \\V_n &= 120 \text{ volts}\end{aligned}$$

The resistance of Starbars increases gradually during their service life. Therefore some means of keeping the power input to the kiln or furnace at a level sufficiently high to maintain the desired temperature is required.

Historically, expensive voltage varying equipment such as multiple tap transformers were recommended for all but the very low temperature applications.

Starbars can be used directly on the line (fixed voltages) at temperatures up to 2400°F (1315°C). To compensate for the reduced output as the Starbars gradually age or increase in resistance, the furnace or kiln is initially overpowered by 25% to 50%. This type of arrangement eliminates the expensive voltage varying equipment and has proven very satisfactory in many applications. It is not

recommended when fine process temperature control is required.

Assume a furnace will require approximately 22,000 watts after all heat losses and load factors have been considered. Increasing this 22,000 by 25% to 50% gives a wattage requirement of between 27,500 and 33,000 watts.

By taking another look at the previous example of 8 Starbars, it can be seen that 10 Starbars U 23.5 x 12 x 9.5 x 1 connected two in series five parallel groups on 120 volts would supply 28,500 watts. If 12 Starbars of the same size were used, the output would be 34,200 watts. Twelve Starbars connected four in series per phase, these three groups then in a delta, on 240 volts would make a balanced three phase 240 volt network.

The temperature of the kiln or furnace is controlled by an off-on controller. When the Starbars are new they will only be powered for 22/28.5 or 22/34.2 of the time.

As the Starbars increase in resistance they will be on for a greater percentage of the time. When they have increased in resistance to a point at which they supply 22,000 watts, they will be on 100% of the time. A SCR (silicon controlled rectifier) or thyristor can also be substituted for the contactor.

For applications where close temperature control is desired and/or for temperatures above 2400°F (1315°C) a device for increasing the voltage to the Starbars is required. There are several methods of providing this variable voltage source:

- (1) The multiple tap transformer was historically the most common. The secondary of the transformer is provided with taps, which usually vary in number from 10 to 36. By carefully selecting the voltage taps, the correct voltage output to match the resistance of the Starbars over their complete useful life can be made.
- (2) Silicon controlled rectifiers (SCR, also known as a thyristor stack or thyristor unit) have become increasingly popular, as they offer precise fine control of the voltage input to the heating elements.
- (3) A combination of transformers and SCRs, whereby the transformers are used to match the requirements of the load to the voltage supply, but having far fewer taps than conventional transformer only systems, typically 3 to 4 taps only, with the SCR providing the fine control between tap changes.

To compensate for the reduced output as the Starbars increase in resistance, a voltage range is required that will compensate for a 100% increase in the Starbar resistance.

The following formula may be used to calculate V_{max} :
 $V_{max} = \sqrt{(Wt \times R_n) \times 1.5}$, V_{max} = recommended maximum voltage required to compensate for increase in resistance due to aging and resistance tolerance, Wt = rating of transformer in watts, R_n = network resistance of the Starbars, 1.5 = minimum margin to accommodate the doubling of the Starbar resistance and the plus 20% resistance tolerance. A higher value will offer slightly longer usable service life.

Table A

Starbar Nominal Leg Diameter		Ohms per Leg Hot Zone		Ohms per Leg Cold Ends	
mm	inch	Ohms / mm	Ohms / inch	Ohms / mm	Ohms / inch
13	1/2	0.00764	0.19410	0.000387	0.00982
16	5/8	0.00490	0.12450	0.000248	0.00631
19	3/4	0.00346	0.08790	0.000170	0.00433
25	1	0.00200	0.05100	0.000098	0.00250
32	1-1/4	0.00126	0.03200	0.000067	0.00171
35	1-3/8	0.00106	0.02693	0.000053	0.00135
38	*1-1/2	0.00083	0.02120	0.000046	0.00117
44	*1-3/4	0.00065	0.01650	0.000032	0.00082
54	*2-1/8	0.00059	0.01490	0.000030	0.00075

**All resistance values are +/-20%.

To determine the resistance of a U type Starbar; select the diameter then obtain the resistance values from Table A, then:

- 1) Multiply the ohms/leg hot zone x hot zone length x 2 (number of legs)
- 2) Multiply the ohms/leg cold end x cold end length x 2 (number of cold ends)
- 3) Add the total hot zone resistance to the total cold end resistance

Type W Starbars are typically connected to a three-phase line; therefore the resistance value for each leg is required. To determine the resistance on one leg, select the diameter from Table A, then:

- 1) Multiply the ohms/leg hot zone x hot zone length
- 2) Multiple the ohms/leg cold end x cold end length
- 3) Add the hot zone resistance to the cold end resistance.

Example: The transformer is rated at 22.8 KVA and has a computed nominal full load voltage of 120 volts. (Rn = 0.635, Wt =22,800)

$$V_{max} = \sqrt{(Wt \times Rn) \times 1.5}$$

$$V_{max} = \sqrt{(22,800 \times 0.635) \times 1.5}$$

$$V_{max} = \sqrt{(14,478) \times 1.5}$$

$$V_{max} = 180 \text{ volts}$$

The nominal full load voltage and maximum voltage have been computed. When specifying the transformer, the nominal full load voltage is usually reduced to allow for the minus 20% resistance tolerance of the Starbars and slow furnace heat-up.

To calculate the minimum voltage, take 70% of the nominal voltage. For periodic applications, take 30% of the nominal full load voltage. Auto transformers may be used if primary voltage is 230 volts or less. They should not be used in a three phase arrangement. Accepted practice limits the secondary voltage on all transformers to 300 volts. Above this, refractory voltage leakage becomes a problem.

When computing the size of the voltage steps between taps, a value of 5% of the nominal full load voltage is often used. When SCR or thyristor controls are used on the primary, fewer taps are required. For example, if 6 taps are used, the idling tap can be 0.7 x nominal voltage, then each consecutive tap would be 14% higher. For 8 taps, the idling tap would again be 0.7 x nominal voltage, each consecutive tap at 9.1% higher than the preceding value.

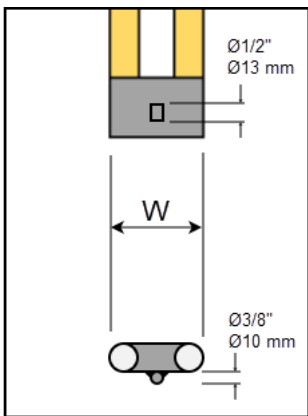

-Optional-
Self-aligning pivot
support pin bonded into
bridge for horizontal
installations.

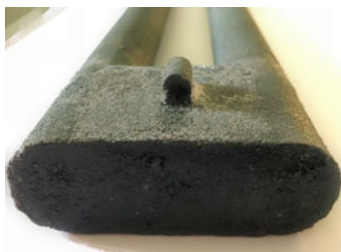

Table B
Hardware Supplied with U & W

Starbar Nominal Leg Diameter		Stainless Steel Support Washer				Stainless Steel Cotter Support Pin			
		OD		ID		Diameter		Length	
mm	inch	mm	inch	mm	inch	mm	inch	mm	inch
13	1/2	21	53/64	14	9/16	3	1/8	51	2
16	5/8	27	1-1/16	17	21/32	3	1/8	51	2
19	3/4	30	1-3/16	20	25/32	3	1/8	51	2
25	1	44	1-3/4	27	1-1/16	3	1/8	51	2
32	1-1/4	55	2-5/32	33	1-5/16	4	5/32	76	3
35	1-3/8	55	2-5/32	37	1-7/16	4	5/32	76	3
38	1-1/2	64	2-1/2	40	1-9/16	4	5/32	76	3
44	1-3/4	73	2-7/8	48	1-7/8	4	5/32	76	3
54	2-1/8	85	3-21/64	56	2-7/32	4	5/32	76	3

SUPPORT HARDWARE
Figure 3

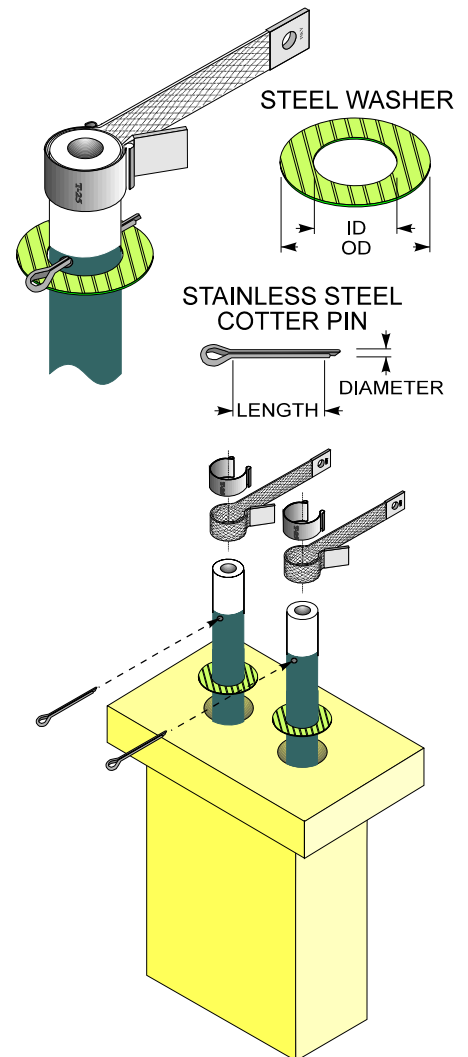

Table C
Recommended Minimum Refractory Hole Size

Starbar Nominal Leg Diameter		Minimum Hole Diameter Based on Refractory Wall or Plug Thickness									
		100	150	200	300	400	3	5	6.5	9	13.5
MM	Inch	MM	MM	MM	MM	MM	Inch	Inch	Inch	Inch	Inch
13	1/2	18	19	20	22	--	11/16	3/4	3/4	13/16	--
16	5/8	21	22	23	25	--	13/16	7/8	7/8	15/16	--
19	3/4	25	25	26	28	--	15/16	1	1	1-1/16	--
25	1	31	32	33	35	37	1-3/16	1-3/16	1-1/4	1-1/4	1-7/16
32	1-1/4	38	39	40	42	44	1-1/2	1-1/2	1-9/16	1-9/16	1-11/16
35	1-3/8	41	41	43	45	47	1-5/8	1-5/8	1-11/16	1-3/4	1-7/8
38	1-1/2	45	45	46	48	50	1-3/4	1-3/4	1-13/16	1-7/8	1-15/16
44	1-3/4	51	52	53	55	57	2	2-1/16	2-1/16	2-1/8	2-3/16
54	2-1/8	61	62	63	65	67	2-3/8	2-7/16	2-7/16	2-1/2	2-9/16

EASE OF REPLACEMENT

Starbars can be replaced while the furnace is at operating temperature without danger of thermal shock damage. Because of the multiple leg configuration, these Starbars are often installed through a refractory plug as shown in Figure 3, page 5. In this way, the entire plug and Starbar assembly can be removed from the outside of the furnace.

SERVICE LIFE

Starbars increase gradually in resistance with use. This characteristic of increasing in resistance is called aging.

Aging is a function of the following:

1. Operating temperature
2. Electrical loading (usually expressed in watts per square inch or watts per square centimeter of Starbar radiating surface)
3. Atmosphere
4. Type of operation (continuous or intermittent)
5. Operating and maintenance techniques

MOUNTING

There are no restrictions on the mounting positions of Starbars, although the horizontal and vertical positions are common. The most common is vertical with the Starbar being hung from the cold ends. When these Starbars are mounted horizontally the bridge should be supported.

The legs should be positioned in the same horizontal plane, not on edge. If the legs were to be positioned in a vertical plane, it would be difficult to get proper support for each leg. Extreme caution should be used when mounting to ensure that the Starbars are not placed in tension. There should be adequate freedom to allow for the furnace and Starbars to expand and contract independently.

The support hardware, included with each shipment, consists of a stainless steel washer for each leg and two stainless steel cotter pins as shown in Figure 3 and listed in Table B.

Support hardware and support holes are not included for Starbars to be mounted horizontally.

Starbars should have their heating sections in the furnace chamber so that no portion of the heating section extends into the furnace wall or refractory plug.

Starbars should not be placed closer than two Starbar diameters to each other or one and one half Starbar diameters to a wall or other reflecting body. If the Starbar is not able to dissipate heat energy equally in all directions, it may cause local overheating and possible failure. The formula for computing the recommended Starbar spacing to obtain an even temperature gradient on the product being heated is shown in Figure 5.

HORIZONTAL U & W ELEMENTS

As described earlier, it is essential that elements and furnace superstructure are free to expand and contract independently of one another, and that the elements are not placed in tension.

Lead through plugs having enlarged or elongated holes for the element cold ends are necessary, and the support at the far end of the element for the bridge should be on the same horizontal plane as at the front lead through end. The two legs of highly powered U-type Starbar elements can move apart from each other by up to ≈3/8" (10mm), so the lead through design must allow for such movement to take place unrestricted. A smooth horizontal surface to support the cold ends at the connection end will ensure that the element cold ends are able to move back and forth unhindered during thermal cycling. The bridge at the far end of the element should be selected with a self-aligning pivot pin (see figure 3) which ensures that both legs are supported equally without one being placed in tension. The inclusion of a pivot pin in the bridge enables an element to follow the same horizontal plane established at the lead-through end of the element. The principle is that of a three-legged stool. The standard pivot pin is Ø3/8" (Ø10mm) x 1/2" (13mm) long, but other sizes may be supplied on request.

FURNACE HEATING CHAMBER

The furnace heated chamber dimension which the Starbar spans can be the same as the hot zone length of the Starbar as shown in Figure 5. Recommended terminal hole diameters for various refractory walls or plugs and Starbar sizes are shown in Table C, page 6.

SPECIFICATIONS AND MATCHING

Starbars have a manufactured tolerance of ±20% on the nominal resistance. All Starbars are calibrated at least twice prior to shipping to ensure their being within specifications. The calibrated amperage of each Starbar is marked on the carton and one cold end of each Starbar. When installing, arrange Starbars with amperage values as close to each other as available. Longer service life will be obtained when series connected Starbars are matched in resistance. Starbars are shipped as closely matched as possible.

REFRACTORY PLUGS

If refractory plugs are used, multiple leg Starbars can be installed from outside the furnace. A plug works the same as a large removable refractory brick. I Squared R can manufacture cast refractory plugs. If both the Starbars and the plugs are supplied, the fit between the two are guaranteed to be correct. Unless otherwise specified the material used is a 2800°F (1535°C) 145 pound density cast refractory. A one inch (25mm) cross section flange is used to support the weight of the plug and Starbar. The plugs are available in both rectangular and cylindrical cross sections, see Figure 4.

BRIDGE CONSTRUCTION

The bridge construction of the multiple leg Starbars is unique. Unlike others available in the market, the Starbar bridge is flush, not extending beyond the hot zone diameter. Custom bridge widths are available.

Mechanical failures have historically been most frequent at or just above the bridge. The Starbar construction addresses this by eliminating any welds in this area. The hot zone material extends to the very end of the element. The bridge is two leg diameters high and is not self-heating.

AVAILABILITY

Starbars can be shipped from stock, or two to three weeks after receipt of an order.

CUSTOM CONFIGURATIONS

Special sizes and shapes are available. For example the RU, illustrated on page 8, has all the electrical characteristics of the U Starbar. The cold ends are attached perpendicular to the hot zone. The RU is normally installed with the cold end through the wall of the furnace. Special consideration must be made to keep the hot zone a sufficient distance from the hot face.

CAST REFRACTORY PLUGS
Figure 4

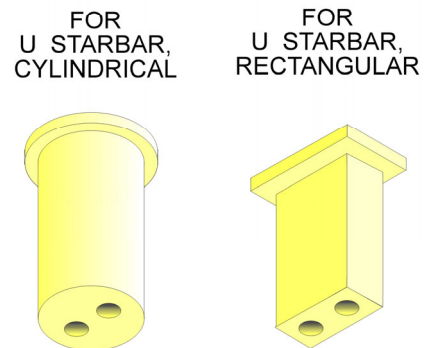

Table D
U & W type Starbar Dimensions

Starbar Nominal Leg Diameter		**OC Minimum (Recommended) for U & W		**OC Maximum U & W		Bridge Height		*** Maximum Recommended Overall Length	
mm	in.	mm	in.	mm	in.	mm	in.	mm	in.
13	1/2	25	1.00	76	3.00	25	1.00	711	28
16	5/8	32	1.25	76	3.00	32	1.25	890	35
19	3/4	38	1.50	102	4.00	38	1.50	1020	40
25	1	51	2.00	102	4.00	51	2.00	1270	50
32	1-1/4	64	2.50	102	4.00	64	2.50	1525	60
35	1-3/8	70	2.75	102	4.00	70	2.75	1525	60
38	1-1/2	76	3.00	127	5.00	76	3.00	1525	60
44	1-3/4	89	3.50	127	5.00	89	3.50	1525	60
54	2-1/8	102	4.00	127	5.00	102	4.00	1525	60

Support Hole diameter for all diameters is .21" (5.3mm)

** OC = On center spacing or distance measured from the center of one leg to the center of the next.

***Maximum Recommended Overall Length should not be exceeded if possible. Longer lengths are available. Please contact us for additional handling and shipping precautions.

Figure 5

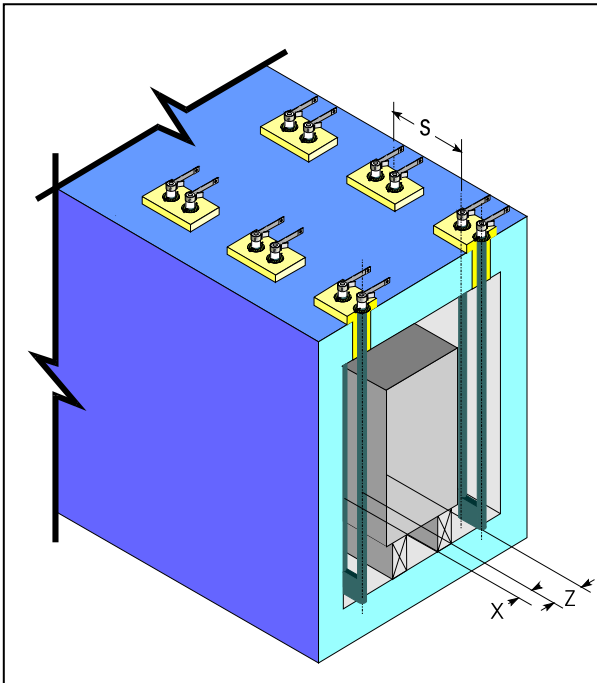

Recommended Starbar Spacing

- X = 2 leg diameter is the minimum, 1.5 x Starbar leg diameter is the absolute minimum and requires a reduced Starbar surface watt loading
- Z = $S / 1.41$ Minimum for Stationary Loads.
- Z = $S / 1.73$ Minimum for Moving Loads.
- S = 2 x Starbar Leg Diameter Minimum.
- X -- the distance from the centerline of the Starbar leg to any other reflecting surface, such as a refractory wall or product.
- Z -- the distance from the centerline of the Starbar leg to a moving or stationary load.
- S -- the distance from the centerline of the Starbar leg to the centerline of an adjacent Starbar leg.

W TYPE STARBAR

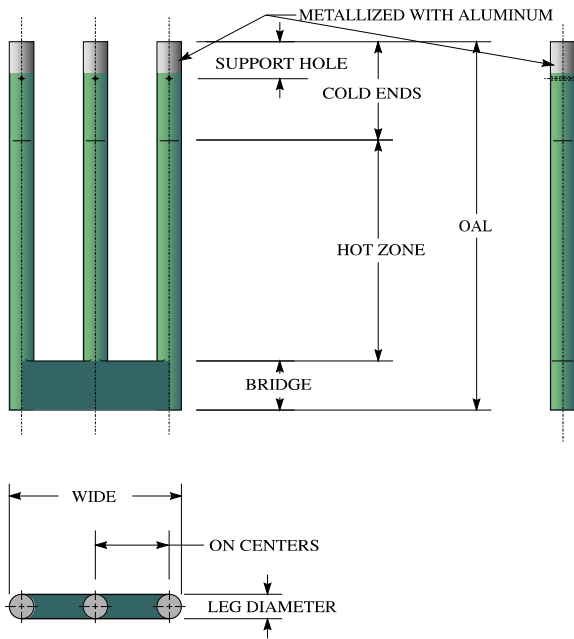

RU STARBAR

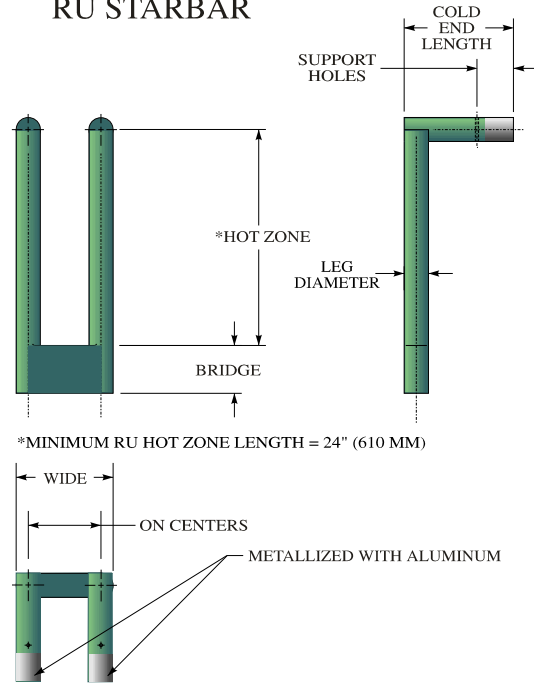

Part Number Designations

OAL = Overall Length of Starbar
 HZ = Hot Zone Length
 CE = Cold End Length
 C = On-Center Leg Spacing,
 SH = Support hole location (measured from electrical end of the cold end)

Example: U 24.0x12.0x10.0x1.00 SH = 3, C = 3

U, W	OAL x	HZ x	CE x	DIA	SH = , C=
RU		HZ x	CE x	DIA	SH = , C=

Also specify nominal element resistance, Ω