

Moly-D[®]

TECHNICAL HANDBOOK

*High Temperature
Heating Elements
for Electric Furnaces*



Moly-D heating elements are made in U.S.A.

www.isquaredrelement.com

Phone: (716) 542-5511, FAX: (716) 542-2100

Moly-D[®]

**Molybdenum
Disilicide
Heating Elements**



I SQUARED R ELEMENT CO., INC.

TABLE OF CONTENTS

General description	2
Properties	2
First Firing	2
Maximum element temperature in various atmospheres	3
Maximum element temperature in a vacuum	3
Mechanical and physical characteristics of Moly-D material	3
Maximum amperes	3
Resistance characteristics	4
Obtaining hot zone length (Le)	5
Maximum hot zone lengths	5
Calculating power	5
Calculating total length	5
Standard "a" dimension	5
Calculating hot zone surface area	5
Calculating watt loading	6
Calculating element power	6
Calculating hot zone resistance	7
Cold end length outside furnace	7
Cold end taper length inside furnace	7
Calculating cold end resistance	8
Calculating total element resistance	8
Calculating distance to wall parallel	8
Calculating distance to wall perpendicular	9
Calculating bowing distance of hot zones	8
Calculating distance to the floor	9
Calculating distance between parallel elements	10
Calculating the wall length	10
Calculating the number of elements along the wall	10
Calculating resistance and length of multishank elements	11
Elements with bend in Le or Lu	11
Recommendations for wiring connections	12
Element holders and straps	13

GENERAL DESCRIPTION

The Moly-D element is a dense cermet material consisting of molybdenum disilicide (MoSi_2) and a glassy phase silicon dioxide (SiO_2). They can be operated at element temperatures up to 1775°C .

The elements are U shaped and are most frequently used suspended with the bottom of the "U" down. The element consists of two cold ends (Lu) and a U-shaped hot section (Le). The cold ends are twice the diameter of the hot section and are attached by a weld. The extremities of the cold ends are metallized with aluminum to provide a low-resistance contact surface to which the electrical connections are made with flat braided aluminum straps.

The Moly-D elements are described by the grade MD-31 or MD-33, the diameter of the hot section, the diameter of the cold end, the length of the cold end (Lu), the length of the hot zone (Le) and the distance between the two legs (a). The dimensions are in millimeters (mm). Example: MD-33 $3/6 \text{ Lu}=150 \text{ Le}=180 \text{ a}=25$ completely describes the element.

The Moly-D element is a resistance type heating element that converts electrical energy to heat energy (Joules Law $W = I^2R$).

PROPERTIES

1. Manufactured to industry established diameters and resistance values in the following diameters: 3/6, 4/9, 6/12, 9/18 and 12/24 and hot zone lengths up to 1400mm long.
2. Moly-D elements may be used at surface temperature up to 1775°C (3230°F), at control furnace temperatures up to 1750°C (3182°F) in oxidizing atmospheres. Lower temperatures are recommended in reducing atmospheres.
3. They provide long service life, ease of replacement, and low maintenance costs.
4. New and old elements can be operated in the same control group.
5. Multiple elements can be connected in series.
6. They have a high power rating, example 22.6 watts per square centimeter at 1450°C (2642°F) furnace temperature.
7. The high power makes possible rapid increases in furnace temperature.
8. They can be used continuously or intermittently.

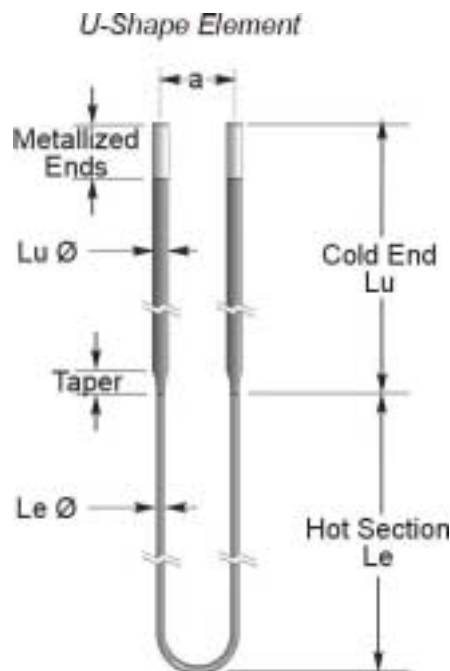

STANDARD ELEMENT SIZE

Element Le/Lu Ø mm	"a" Distance between legs		Le Ø mm	Lu Ø mm	"g" taper Length mm	Metal- lized Ends mm
	Min	Std				
3/6	20	25	3	6	15	25
4/9	20	25	4	9	18	40
6/12	40	50	6	12	25	40
9/18	50	60	9	18	30	75
12/24	60	80	12	24	40	100

TWO GRADES ARE OFFERED

Type MD-31 - Maximum element temperature -- 1700°C (3090°F).

Type MD-33 - Maximum element temperature -- 1800°C (3270°F).

The MD-33 is a higher temperature material and is recommended only when the element temperature exceeds 1700°C . The MD-33 costs more than the MD-31 and there is no increase in element life for the MD-33 if operated below the 1700°C element temperature.

FIRST FIRING

When the elements are new (first used) they must be brought to an element temperature of 1200°C or higher quickly in air. If operated at a surface temperature in the 500°C to 700°C range for any length of time, the elements will be destroyed. After the glaze is formed, the element may be operated at low temperatures as long as the glaze is intact.

ELEMENT OPERATING TEMPERATURES

Moly-D elements can be operated at temperatures up to 1800°C in an oxidizing atmosphere. They can be used in reducing and neutral atmospheres at lower element temperatures.

Table A shows the maximum recommended element temperature for various atmospheres.

Table A MAXIMUM RECOMMENDED ELEMENT TEMPERATURES IN VARIOUS ATMOSPHERES		
Atmosphere	MD-31 °C	MD-33 °C
Air	1700	1800
Nitrogen	1600	1700
Argon, helium	1600	1700
Dry Hydrogen, dewpoint -80°C	1150	1150
Moist hydrogen, dewpoint 20°C	1450	1450
Exogas	1600	1700
Endogas	1400	1450
Disassociated ammonia	1400	1400
Any members of the Halogen group will attack the silicon dioxide on the element, therefore should be avoided.		
<i>For any special atmospheres, please contact the factory.</i>		

Prior to operating the element in neutral or reducing atmospheres, it is important that they be operated over 1200°C in air to build up the silicon dioxide protective coating. Thirty minutes is usually a sufficient time. For longer life in reducing or neutral atmospheres, the element should be operated periodically at 1200°C or higher in air to replace and insure a strong protective SiO₂ coating.

MECHANICAL AND PHYSICAL CHARACTERISTICS OF MOLYBDENUM DISILICIDE

Density:	5.6 g/cm ³
Porosity:	~1%
Thermal conductivity:	
20-600°C	30 W/m-°K 208 BTU/hr-ft ² -°F/in
601-1200°C	15 W/m-°K 104 BTU/hr-ft ² -°F/in
Coefficient of linear expansion: . .	7.5 x 10 ⁻⁶ °C 4.1 x 10 ⁻⁶ °F
Specific heat capacity at 20°C: . .	420 J/kg-°K 0.10 BTU/lb-°F
Emissivity:	0.70 - 0.80
Resistivity of Moly D material: . . .	page 4, graph 2

VACUUM

Graph 1 shows the maximum recommended element temperature under various vacuum conditions. Pure molybdenum or graphite is usually a better choice of a material for high vacuum furnaces.

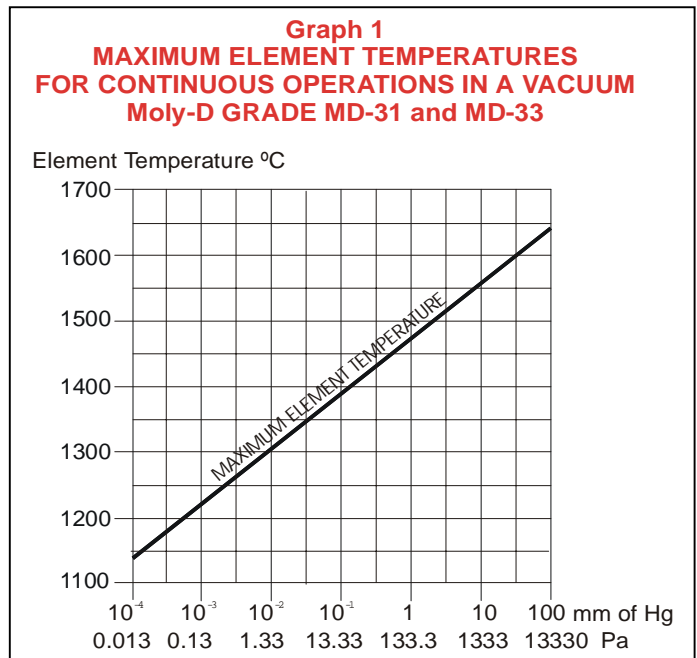

Various units of measurement are used in the vacuum industry. A reference is provided:

- 1 atmosphere
- = 760 mm of Mercury (mm Hg)
- = 760 Torrs
- = 760,000 microns
- = 101,325 Pascals (Pa)
- = 101,325 Newtons per square meter (N/m²)
- = 1,013,250 Dyne/cm²
- = 1.013 Bar
- = 14.69 pounds per square inch (psi)

MAXIMUM AMPERES

The Moly-D elements are low-voltage high-current elements. Below is the maximum recommended current for each standard hot zone diameter. The hot zones can take more power but the cold ends tend to over heat and cause strap and clamp failure.

Maximum Recommended Amperes					
Hot Zone Diameter in mm	3	4	6	9	12
Current Amperes	75	115	200	365	560

RESISTANCE CHARACTERISTICS

The Moly-D heating element is a resistant type heater that converts electrical energy to heat energy according to Joules Law $W=I^2R$. W = Power in watts, I = Current in amperes, R = Resistance in ohms. Molybdenum disilicide increases in resistance by a factor of approximately 10 between 20°C and 1800°C. See graph 2. Therefore the hot zone temperature must be known before the resistance of the hot zone can be determined.

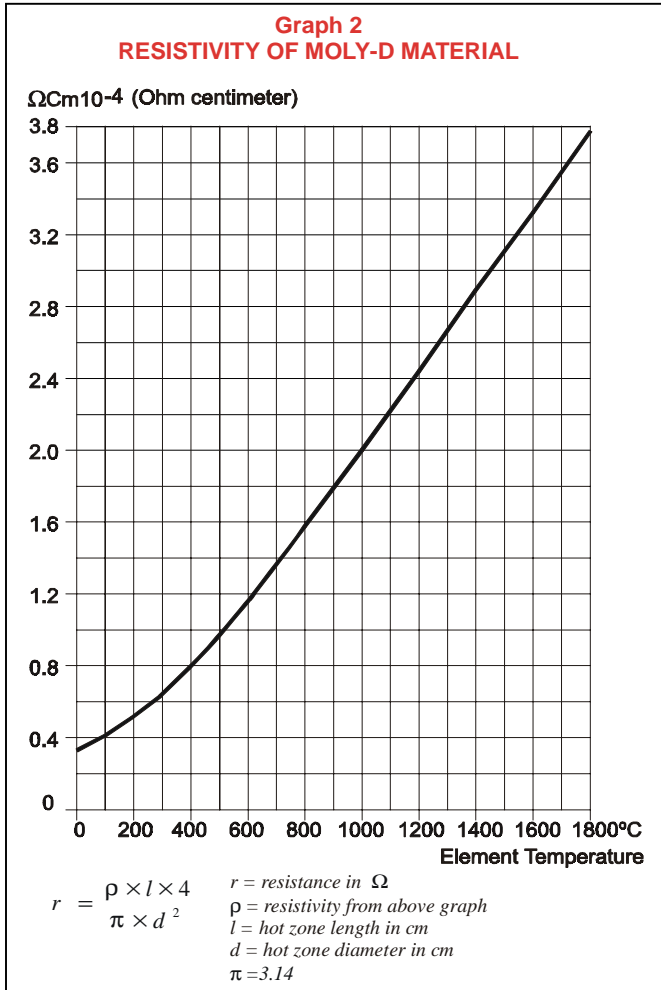

The scientific community and resistance wire manufacturers have standardized on the unit ohm-centimeter for resistivity. The ohm-centimeter is the resistance of the material with a cross sectional area of one square centimeter (1 cm^2), one centimeter (1 cm) in length.

To obtain the resistance of a 3mm diameter hot zone one mm in length at 1675°C, use the equation

$$r = \frac{\rho \times l \times 4}{\pi \times d^2} \text{ from graph 2 select element temperature}$$

of 1675° and follow this line until it intersects the heavy black line. Then follow the horizontal line to the left and record resistivity $\rho = 3.48 \times 10^{-4} \Omega \text{ cm}$

$l = \text{hot zone length in cm (0.1 cm)}$
 $d = \text{diameter of element in cm (0.3 cm)}$
 $4 = \text{to convert diameter to radius}$

$$r = \frac{3.48 \times 10^{-4} \times 0.1 \text{ cm} \times 4}{\pi \times 0.3^2 \text{ cm}}$$

$$= \frac{.000348 \times .4}{0.2826}$$

$$= 0.000493 \Omega$$

$$= 4.93 \times 10^{-4} \Omega$$

The (r) is the resistance of 3mm diameter hot zone 1mm long at 1675°C.

The same method can be used to compute the resistance of any rod diameter of any length at any temperature. A simpler method is shown below.

The Moly-D element is a high temperature element that performs well and gives long service life at its rated temperature of 1700°C or 1800°C. Therefore, we recommend designing to element temperatures of 1675°C for the grade MD-31 and 1775°C for the grade MD-33 in air.

The resistance values for 1mm of length for standard element diameters at 1675°C and 1775°C are shown on Table B.

Table B

Hot Section Diameter	r Resistance in ohms per mm of length @ 1675°C and 1775°C	
	MD-31 1675°C	MD-33 1775°C
3	.000493	.000523
4	.000277	.000294
6	.000123	.000131
9	.000054	.000058
12	.000030	.000032
18	.000013	.000014

The resistance temperature characteristic of the Moly-D element material is almost linear from 1800°C down to 1400°C. To estimate the resistance at lower hot zone temperatures, multiply the higher temperature resistance by 0.94 for each 100°C decrease in hot zone temperature.

The estimated resistance of a MD-31, 6mm diameter hot zone, 1mm long, at 1575°C is: (r_{1675} from table B).

$$r_{1575} = (r_{1675})(.94)$$

$$r_{1575} = 0.000123(.94)$$

$$r_{1575} = 0.000116 \Omega / \text{mm}$$

OBTAINING THE LENGTH OF THE HOT ZONE (Le)

The molybdenum disilicide softens at temperatures over 1200°C therefore will elongate or stretch when suspended vertically. The heating element can be destroyed if it comes in contact with the floor of the furnace while hot and under power. To allow for the increase in length and keep it a safe distance above the floor, the hot zone (Le) must be shorter than the heated chamber height.

To obtain the length of the hot zone, two steps are required.

1. At the location in the furnace where the elements are suspended, determine the height (H) in millimeters.
2. The taper portion of the cold end (Lu) extends into the hot chamber. This cold end taper length varies with the diameter of the element. See Table D to obtain the taper length (g) inside the hot chamber.

To obtain the hot zone length (Le) use one of the following formulas:

$$\text{for } H \text{ less than } 200\text{mm} \quad L_e = H - 10 - g$$

$$\text{for } H \text{ over } 200\text{mm} \quad L_e = 0.95H - g$$

H = height of furnace in mm.

g = taper length in mm from Table D.

10 = minimum recommended vertical distance beneath the element in mm.

0.95 = shortening of the Le to allow for the element to stretch and be a safe distance above the floor.

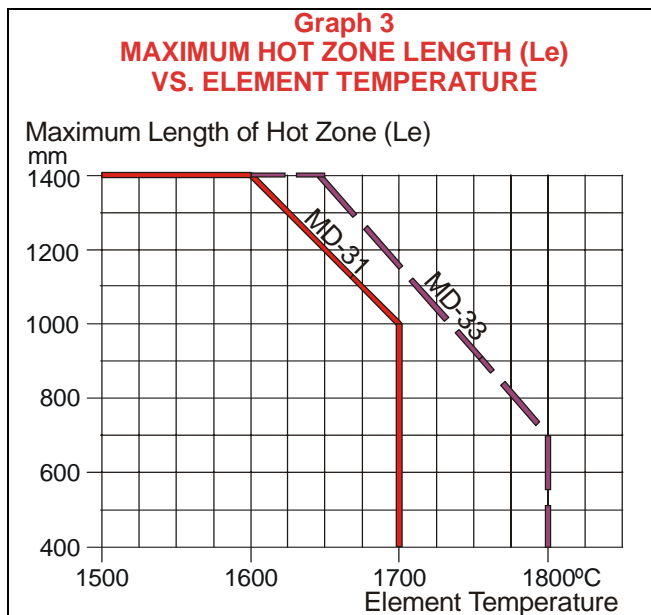

The following are maximum length limitations on the hot sections: 3/6 and 4/9 maximum Le = 400mm
6/12, 9/18 and 12/24 maximum Le = 1400mm

The 6/12, 9/18 and 12/24 maximum lengths are reduced based on element temperatures over 1600°C, see graph 3.

METHOD TO COMPUTE THE POWER ON A U-SHAPED MOLY-D ELEMENT

To compute the power in watts on the Moly-D element the length of the hot zone, the surface area of the hot zone, and the watt loading in watts per cm² must be determined.

The heating length of a “U” shaped element consists of 2 legs and a 180° bend. The heating length for the 180° bends for various (a) dimensions is shown in Table C, column 3.

Step 1

To obtain the total length of the hot zone in mm, use the equation: Total Hot Zone (L_H) = 2(L_e) plus (z) the amount from Table C, column 3.

$$L_H = 2(L_e) + z$$

1	2	3	4
Hot Zone Diameter mm	On-Center mm <i>a</i>	Length to be added to Le mm <i>z</i>	Surface Area (mm ²) for 1 mm of length <i>c</i>
3	20	28	9.42
3	25	31	9.42
4	20	27	12.56
4	25	30	12.56
6	40	37	18.84
6	50	42	18.84
6	60	48	18.84
9	50	40	28.26
9	60	45	28.26
12	60	42	37.68
12	80	54	37.68
18			56.52
24			75.36

Step 2

To obtain the surface area (SA) of this hot zone in square cm, select from Table C, column 4, the surface area (c) of 1 mm length for the element diameter 3, 4, 6, 9, 12, or 24 mm. Multiply this by the total from step 1 (L_H). This number will be the total surface area of the hot zone in square mm. To convert the units from square mm to square centimeters (cm), divide by 100.

$$SA = \frac{(L_H)(c)}{100}$$

OBTAINING THE WATT LOADING

The element surface temperature depends on the furnace temperature and the watt loading. When determining watt loading, the maximum furnace temperature and the atmosphere are used.

Step 3

To obtain the maximum recommended watt loading (WL) in air from Graph 4, select on the vertical line the maximum furnace temperature required. Follow this vertical line until it intersects the maximum element temperature line for either the MD-31 or MD-33 element. Select the watt loading line at this intersection. To be on the safe side, reduce the selected value by 3 watts/cm².

Step 4

To obtain the maximum recommended watt loading (WL) for various atmospheres or in a vacuum, the maximum element temperature is required.

The maximum element temperature for various atmospheres is shown on page 3, Table A, in a vacuum page 3, Graph 1.

From Graph 4 select the furnace temperature line and follow the line vertically until it intersects the horizontal element temperature line. Select the watt loading line (WL) at this intersection. To be on the safe side, reduce this value by 3 watts/cm².

Step 5

To obtain the element power in watts (P), take the watts per square centimeter (WL) from step 4 and multiply it by the surface area of the element computed in step 2 (SA).

$$P = WL \times SA$$

The number calculated is the maximum recommended power in watts for this hot section at the maximum furnace temperature selected.

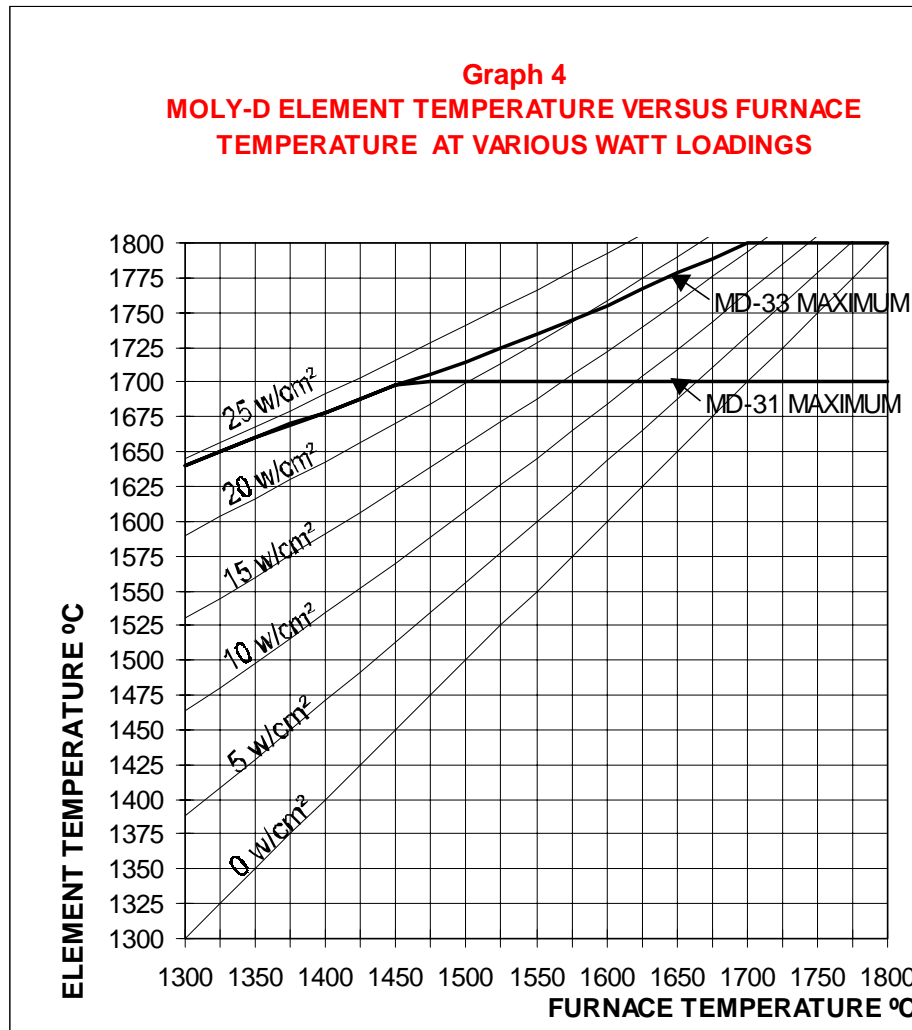

METHOD TO COMPUTE THE RESISTANCE OF THE HOT ZONE L_e

Step 6

The molybdenum disilicide heating element material increases in resistance by a factor of approximately 10 between 20°C and 1800°C. To obtain the resistance, an industry established method has been developed to compute the resistance.

The equation to compute the resistance (r_{me}) for a 1000mm long rod in diameters of 3, 4, 6, 9, 12, 18, and 24 mm at temperatures from 700°C to 1800°C is shown below:

$$r_{me} = \frac{0.0028 \times T_e - 0.255}{d^2}$$

r_{me} = resistance of 1000mm of hot zone in ohms
 0.0028 = the resistivity factor
 T_e = Hot zone surface temperature in °C
 0.255 = correction factor
 d = the diameter of the hot zone

Step 7

To obtain the resistance (r_e) of the hot zone (L_e), use the following equation:

$$r_e = \frac{r_{me} \times L_H}{1000}$$

r_{me} = resistance of the 1000mm of hot zone from step 6
 L_H = Total hot zone length in mm from Step 1

To obtain the total resistance of the element, the cold end resistance must be known too.

METHOD TO COMPUTE THE LENGTH AND RESISTANCE OF THE COLD END (L_u)

No one has yet designed a method of mechanically connecting metallic electrical conductors to a molybdenum disilicide hot section at operating temperature.

Therefore, a cold end of larger diameter molybdenum disilicide is upset butt welded to the smaller diameter hot section. This larger diameter with a lower resistance will operate at a lower temperature making it possible to make the electric connection with an aluminum-braided strap.

The cold end diameter has twice the hot section diameter with the exception of the 4/9mm element.

Step 8

The length of the cold end (L_u) has three factors.

- A portion of the cold end must protrude outside the furnace wall. The electrical connections must be made outside of the insulation to keep them cool. Below in Table D are the minimum protrusion values L_c . Don't reduce these values for doing so could cause the straps to over heat and fail. Select longer rather than shorter lengths.
- The next portion of the cold end is the length that is in the insulating wall L_i . To obtain this dimension, measure the distance from the outside surface of the furnace to the inside surface of the insulation in mm.
- The third portion of the cold end is the tapered (g), that is the reduced diameter portion. This tapered part must extend into the furnace chamber. It must not be in the wall or it will overheat and fail. These values are listed in Table D.

Element Size	3/6	4/9	6/12	9/18	12/24
Protrusion outside the furnace Lc	75 mm	75 mm	100 mm	125 mm	150 mm
Taper Length Inside Chamber g	15 mm	15 mm	25 mm	30 mm	40 mm

To obtain the cold end length (L_u) select the element diameter and add the two vertical numbers from Table D plus the wall thickness measured L_i .

$$L_u = L_c + L_i + g$$

The resistance of the molybdenum disilicide material will increase in resistance approximately 10 times from 20°C to 1800°C element temperature. Therefore the resistance along the length of the cold end will have a wide resistance range for one end is at the furnace temperature and the other end is in the terminal compartment with a much lower temperature.

Step 9

To obtain the resistance of the cold end, an industry established method has been devised that considers the measurements from many tests, the resistivity of the molybdenum disilicide, the furnace temperature, the diameter of the cold end (L_u) and the length of 1000mm of rod.

The simplified calculation is the resistance of 1000mm of cold end.

$$r_{mu} = \frac{0.00196 \times T_f - 0.255}{D^2 L_u}$$

r_{mu} = resistance of 1000mm of cold end
 0.00196 = the resistivity factor
 T_f = the temperature of furnace in degrees centigrade
 0.255 = correction factor
 D_{Lu} = the diameter of the cold end (Lu) mm.

Step 10

To obtain the resistance of the two cold ends (L_u), the equation is:

$$r_u = \frac{r_{mu} \times 2L_u}{1000}$$

r_u = resistance of 2 lengths of L_u
 $2L_u$ = the total length of cold ends for this element, step 8
 r_{mu} = resistance of the 1000mm of cold ends, step 8

Step 11

To obtain the total resistance of the element at operating temperature the equation is:

$$R_t = r_u + r_e$$

R_t = element resistance
 r_e = hot zone resistance, L_e , step 7
 r_u = cold ends resistance L_u , step 10

FACTORS TO CONSIDER WHEN POSITIONING THE ELEMENTS IN THE FURNACE

DISTANCE TO THE WALL (PARALLEL)

Step 12

Moly-D elements are normally supported from the roof or, when bent, the terminal ends are supported by the wall. In most installations the element hot zones are placed parallel to the furnace walls. The element's hot zone surfaces should not contact or be placed close to any surface. The hot zones soften at temperatures over 1100°C and the hot zones can bend toward or away from the wall. The amount of bend is dependent on the hot zone length.

Bending can also be caused by the electrical connections. Short stiff straps that exert pressure on the cold ends can cause the hot zones to bend erratically when they get hot.

When the U shape is placed parallel to the wall and the hot zone (L_e) is less than 300mm in length, the minimum distance (e), see drawing 1, between the centerline of the hot zones and the wall is 15mm. Elements with a hot zone length (L_e) between 300 and 1000, the minimum distance to the wall (e) is obtained by using the equation: $e = (L_e)(.05)$. If the L_e is 1000mm or longer, the minimum distance to the wall is 50mm. The units of the (e) and L_e are in mm.

Example: If the L_e is 1000, the minimum distance to the wall is $e = (1000)(.05)$, $e = 50$ mm.

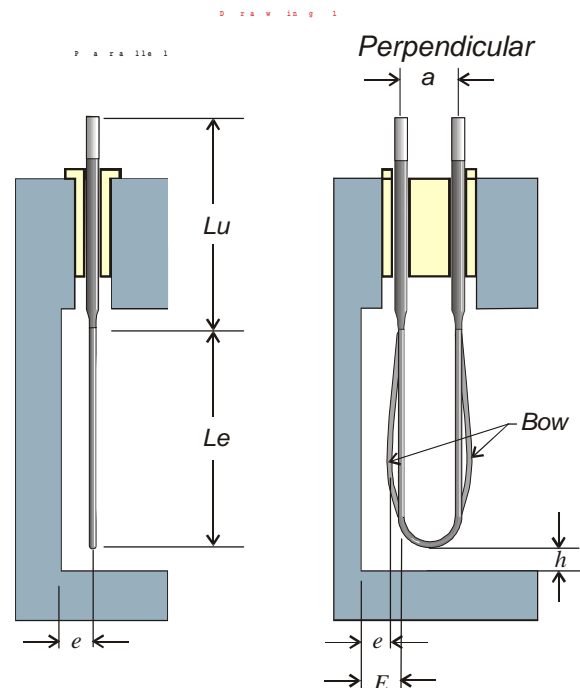

DISTANCE TO THE WALL (PERPENDICULAR)

Step 13

At element temperatures over 1100°C, the electro magnetic forces cause the two parallel legs to bow apart. The amount of bowing is dependent on the hot zone length and watt loading.

The element bowing characteristic must be considered with the first and last element in the parallel row, for they are perpendicular to the corner wall of the furnace.

The minimum distance to the wall (E) in the direction that the element will bow is greater than the parallel distance to the wall (e), see drawing 1.

The maximum bowing would occur with the longest hot zone (1400mm) and the highest watt loading (30 watts per square centimeter).

Knowing the hot zone length (Le) and watt loading, the bow value (f) factor can be obtained from Graph 5.

The (f) factor multiplied by the distance between the legs (a) will provide the total amount of bowing in both directions. To obtain the value of the bow in one direction, toward the wall, the (f)(a) factor must be divided by two. Then one half the (a) distance must be subtracted too for the (E) dimension, Drawing 1, is measured from the leg not from the center of the "U".

Use the following equation to compute the minimum distance to the wall in the direction of the bow (E), see drawing 1.

$$E = e + \frac{(f)(a)}{2} - \frac{a}{2}$$

The (e) is the minimum distance to the wall after the element has bowed and is the same value for an element placed parallel to the wall (Step 12).

Example: Le = 1000, a = 60, watt loading is 30 watts/cm², e = 50mm (step 12), f = 2.3 obtained from Graph 5.

$$\text{Example: } E = 50 + \frac{2.3 \times 60}{2} - \frac{60}{2}$$

$$E = 89\text{mm}$$

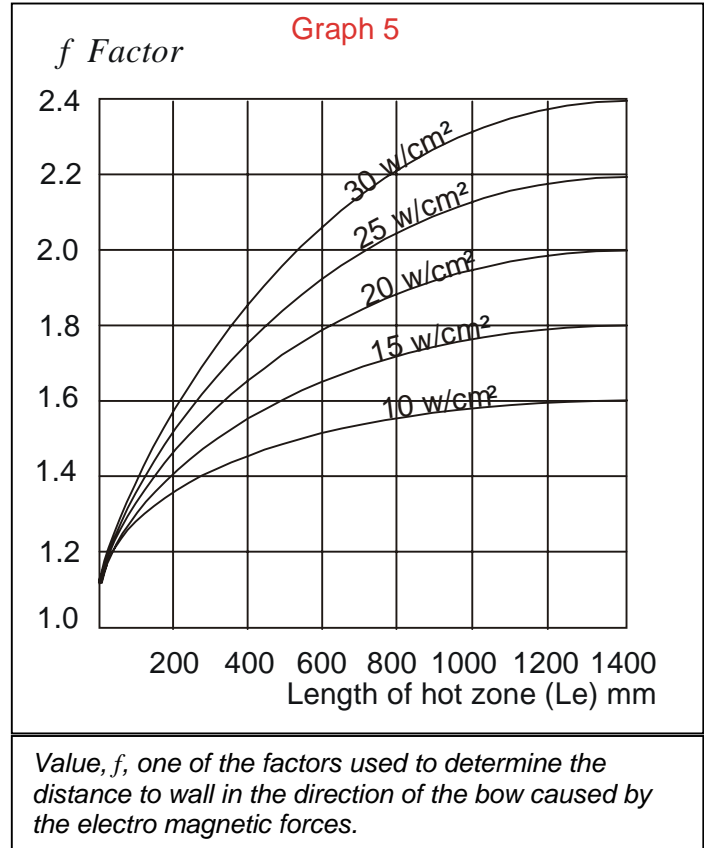

RECOMMENDED DISTANCE TO THE FLOOR

Step 14

The element can be destroyed if it contacts the floor or any debris. Also the Moly-D elements increase in length with use.

The minimum recommended distance (hs) shown in drawing 1 between the bottom of the "U" and the floor is 10mm for elements with an Le of 200mm or shorter. For hot zones (Le) longer than 200, the minimum distance is 5% of the Le.

Example: An element with an Le of 1000mm, the recommended minimum vertical distance to the floor is h = 1000 x .05, h = 50mm

RECOMMENDED ELEMENT TERMINAL HOLE DIAMETER

Table E					
<i>Element Size</i>	3/6	4/9	6/12	9/18	12/24
Element terminal hole diameter	9mm	12mm	15mm	23mm	30mm

RECOMMENDED DISTANCE BETWEEN PARALLEL ELEMENTS

Step 15

It is important to maintain a minimum distance between elements for if they make contact they both will fail. Elements parallel to the wall, that is, in line will bow toward each other. The two closest legs should have a minimum distance as shown in drawing 2.

Graph 6 shows the factor (m) to be used to determine the minimum recommended distance (b) between adjacent element legs. To determine the multiplier (m), the length of the hot zone L_e and the watt loading must be known. Then select the multiplier (m) from graph 6. Then use the equation $b = (a)(m)$ for the minimum distance between adjacent elements:

Example: $L_e = 1000$, $a = 60$, watt loading = 30 w/cm^2
From graph 6, the (m) value is 2.2 then

$$b = (a)(m)$$

$$b = (60)(2.2)$$

$$b = 132\text{mm minimum recommended distance between adjacent legs}$$

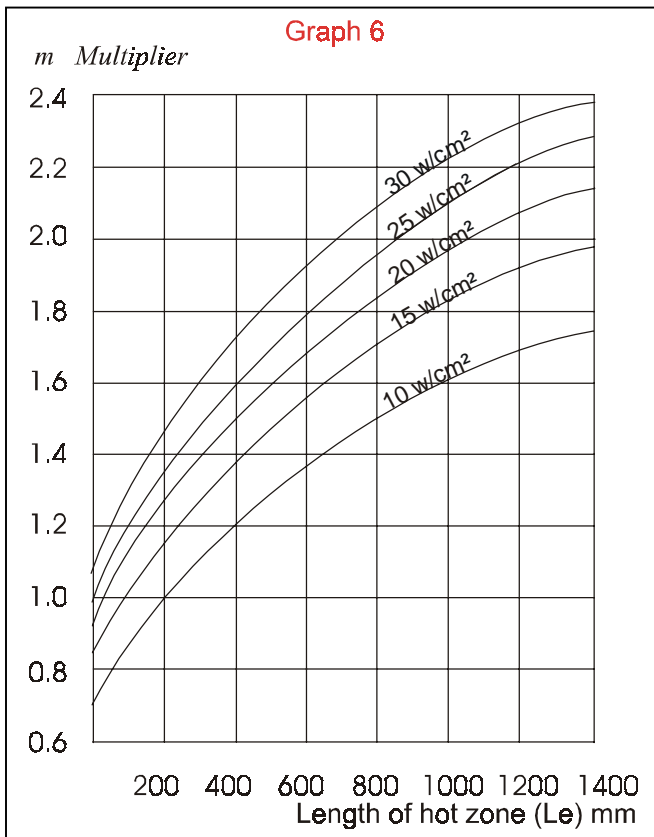

Value m is one of the multipliers used to determine the minimum distance between adjacent legs due to bowing caused by electro magnetic forces.

METHOD TO COMPUTE THE RECOMMENDED WALL LENGTH FOR A PARALLEL LINE OF U-SHAPED ELEMENTS

Step 16

Let the value (L_w) equal the length of the furnace wall. Let (N) equal the number of elements, (a) distance between the element legs, (b) the distance between adjacent legs, and (E) the distance between an element leg adjacent to corner wall for the first and last element in line, see drawing 2.

$$L_w = (N)(a + b) + 2E - b$$

Example: $N = 4$ number of elements
 $a = 60\text{mm leg spacing}$
 $b = 132\text{mm distance between adjacent legs, step 15}$
 $E = 89$ leg distance to wall, step 13

$$L_w = (4)(60+132) + 2(89) - 132$$

$$L_w = 768 + 178 - 132$$

$$L_w = 814\text{mm (minimum wall length)}$$

If the length of the wall (L_w) is known and the number of elements that can be placed along the wall (N) is unknown, use the equation:

$$N = (L_w - 2E + b) \div (a+b)$$

The number of elements must be a whole number. Always reduce to a whole number, never round up.

If more power is required more elements can be fitted into the limited wall length by placing the elements perpendicular to the wall. In some designs as much as 60% more power is available by switching from a parallel to perpendicular arrangement.

Another choice is to make the furnace higher and then increase the hot zone length. Another choice is to select a larger diameter element.

Drawing 2

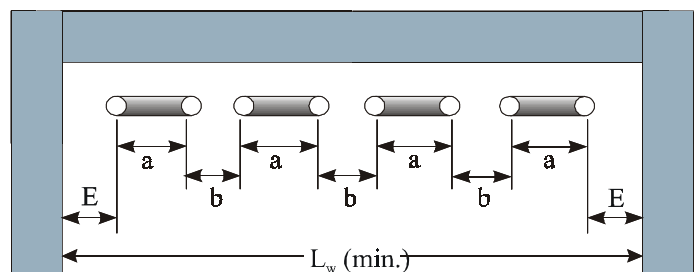

DIFFERENT SHAPES

Moly-D elements can be manufactured in various shapes. The most popular is the “U” shape. The molybdenum disilicide material becomes soft and ductile about 1200°C. Suspending the elements from the cold ends and allowing the hot zone to hang vertically down is the most frequent method of use.

For applications where the vertical height of the hot chamber is small, the use of horizontally mounted elements can be used. In such cases, four-shank or multi-shank elements (as shown in drawing 3) may be used. The surface temperature of the element must not exceed 1600°C. Available in Grade MD-31 in all diameters, they have two advantages over two-shank elements, fewer elements are required and terminal losses are less for there are fewer cold ends.

The element temperature must be limited to 1600°C. The element must be supported. If the element is placed on top of the insulation, no support staples are necessary. If the element is placed on the underside of the roof, support staples holding the element to the insulation are required. If the elements are placed on the side walls of the furnace, they must be held in place by staples.

The method to compute the surface area, watt loading, and power on the multi-shank elements is very similar to the method used with the two shank U-shape elements.

The multi-shank element, as the name implies, has 4 or more shanks. There are always an even number of shanks in the multi-shank element and always one less 180° radius. The middle shanks are shorter than the end shanks.

Step 17

To obtain the total hot zone length of the multi shank element in mm, let NS = number of shanks, Le the length of the outside shanks, and B=length of middle shanks, then use the equation:

$$L_H = 2(Le) + (NS-2)(B) + (NS-1)(z).$$

The value of (z), the length of the 180° bend, is obtained from Table C, column 3.

With the total hot zone length known, the steps 2 through 11 can be used to determine the surface area, power, and resistance of the element. Be sure to limit the element temperature to 1600°C in step 3.

**Drawing 3
MULTI-SHANK ELEMENTS**

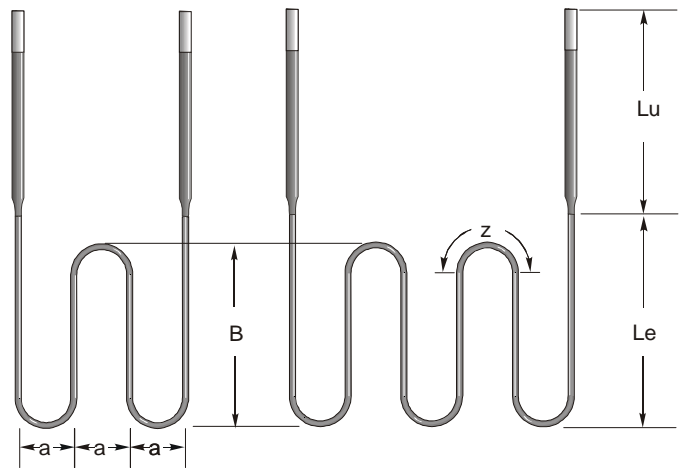

BENDS IN COLD ENDS OR HOT ZONE

The Moly-D element can also be provided with bends in the cold end (Lu) of 30°, 45°, or 90° and with bends in the hot zone (Le) of 90°. The hot zone (Le) is suspended vertically with the bottom of the “U” down. See drawing 4.

**Drawing 4
BENT ELEMENTS**



ELECTRICAL TERMINAL COMPARTMENT RECOMMENDATIONS

Two paralleled conductors, when carrying current, flowing in the same direction will be attracted to each other. If two adjacent Moly-D elements are connected to the same voltage supply, the current will flow in the same direction and the two adjacent legs will be attracted to each other. When the heating elements reach 1200°C, they will soften and be drawn together by the electro magnetic force. When the two elements touch they will both fail.

The two legs of the same element will have the current flowing in an opposite direction therefore tend to separate. The calculation for the distance that they will bow is described on page 10.

The electro magnetic forces must be considered in single phase, two phase, and three phase element arrangements.

Moly-D elements are normally placed on two sides of a furnace or around the circumference in a cylindrical furnace. Never connect the elements so that adjacent elements are connected to the same voltage or power lead.

In a two phase (Scott Connection) or three phase, the same rule applies. Two adjacent elements should not be connected to a common voltage supply. The neutral or ground connection or center of the wye or center of the star can be connected to adjacent element terminal legs. The current is flowing in the same direction but offset a 120° phase difference.

SELECTION OF TERMINAL ACCESSORIES

BRAIDED ALUMINUM STRAPS

The flat braided aluminum straps of the recommended size should always be used. The element terminal ends get hot from the I^2R energy in the cold ends and from the heat conducted from the hot zone out along the cold ends. Using electrical straps of a smaller size or different material can cause the element cold ends and straps to overheat and fail.

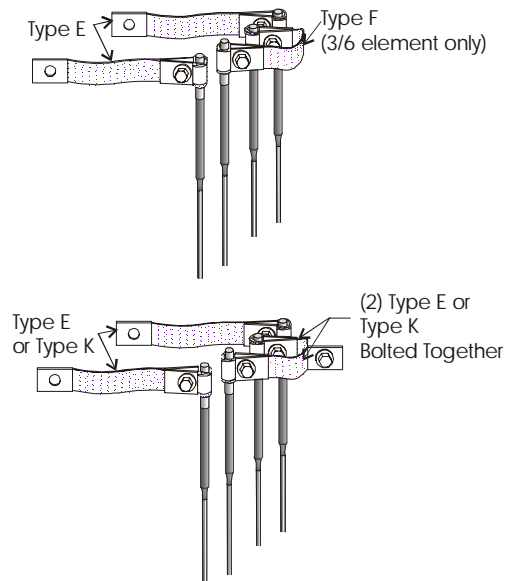

The Moly-D flat braided aluminum straps are type E and

F for the 3/6 element and type K for the 4/9, 6/12, 9/18 and 12/24 elements. The straps are a combination electrical conductor and element clamp. One end of the strap has a loop, which fits over the circumference of the elements aluminized terminal end.

A nut and bolt is provided and is used to tighten the strap to the element.

Although we offer the element to element strap (type F) for the 3/6 element, we don't recommend their use.

We recommend the Type E or K strap be used to connect the element to a post or another Type E or K strap.

It is very important that the strap be initially tightened securely. After the elements are brought to temperature, the nut and bolt should be tightened again. Allow about 24 hours between tightening for the clamp portion of the strap relaxes and becomes loose on the element.

If the clamp is loose, it causes a poor electrical connection that is high in resistance which causes the element terminal end to overheat. This can cause the element and terminal strap to fail.

The strap must not cause a bending movement, i.e. side force on the element. This will cause the heating element to bend and possibly break. We recommend the working length of the strap be a minimum of 12mm longer than the distance between the two connecting points.

ELEMENT MOUNTING

METALLIC HOLDERS

The U-shaped Moly-D elements are hung vertically and must be supported by the cold ends. Metallic holders, similar to shaft collars are used to support the elements. The metallic holder of the correct diameter cold end (size available 6, 9, 12, 18, and 24mm) are fastened to both element cold ends with hex head cap screws.

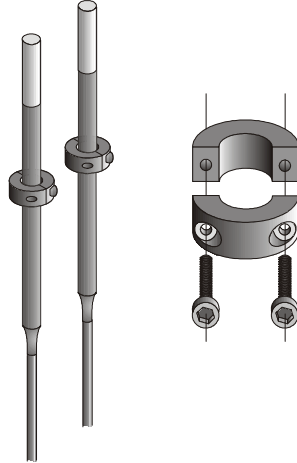

Fasten the metallic holder so that the taper portion of the cold end is not in the furnace wall. If the reduced diameter section is in the wall, the element can over heat and fail. It can also destroy the insulation around the terminal hole.

The element cold end should protrude beyond the furnace shell. The recommended distances are shown on page 7, table D.

The element holder must be tight on the element. If even one holder is loose, that end will slowly fall into the furnace. The hot section is soft over 1200°C and will move towards an adjacent element. This can cause both elements to fail.

If the elements have a bend in the hot section or cold ends the metallic holders should be used. The elements are soft at temperature and frequently move. The metallic holders prevent the element from moving inward.

CERAMIC HOLDERS

Ceramic holders are offered in the 6/12, 9/18, and 12/24 diameters. The ceramic holders are used for higher temperature applications. The stainless steel metallic holders oxidize and are sometimes difficult to remove.

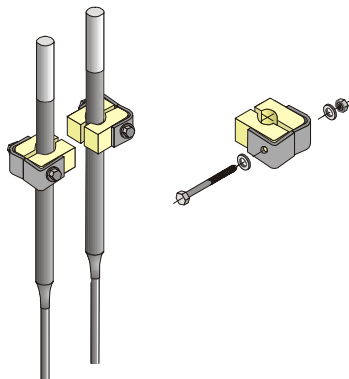

The ceramic holder consists of two moon-shaped ceramic pieces, two stainless steel angle brackets, and a nut and bolt. When assembled the two ceramic pieces are forced together by the tightening of the nut and bolt. This grips the cold end tightly and prevents it from dropping into the furnace.

CERAMIC PLATE HOLDERS

Ceramic Plate Holders are offered in 3/6, 4/9 and 6/12 diameters. Ceramic plates are bolted together squeezing the plates together to keep the element firmly in place.

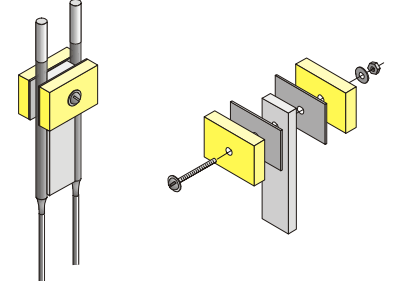

The ceramic plate holder also has a high temperature ceramic fiber insulating board or tab that fits between the two element terminal legs and extends towards the hot zone.

One of the advantages of the ceramic plate holder is that the elements can be installed from the outside of the furnace.

A slot is made in the furnace shell and wall to fit the element diameter and the "a" dimension.

The length of the ceramic fiber tab (LL) should be the thickness of the furnace insulation. The tab should also end where the element taper begins.

The ceramic plate holder is connected to the element and the element carefully inserted in the furnace slot.